

Alcatel-Lucent OAW-AP85 Outdoor Access Point Series



Installation Guide

Copyright

© 2007 Alcatel-Lucent. All rights reserved.
Specifications in this manual are subject to change without notice.
Originated in the USA.

Trademarks

AOS-W, Alcatel 4308, Alcatel 4324, Alcatel 6000, Alcatel 41, Alcatel 60/61/65, Alcatel 70, and Alcatel 80 are trademarks of Alcatel-Lucent in the United States and certain other countries.

Any other trademarks appearing in this manual are the property of their respective companies.

Legal Notice

The use of Alcatel-Lucent switching platforms and software, by all individuals or corporations, to terminate Cisco or Nortel VPN client devices constitutes complete acceptance of liability by that individual or corporation for this action and indemnifies, in full, Alcatel-Lucent from any and all legal actions that might be taken against it with respect to infringement of copyright on behalf of Cisco Systems or Nortel Networks."



www.alcatel-lucent.com

26801 West Agoura Road
Calabasas, CA 91301

Preface	Guide Overview	5
	Related Documents	5
	Contacting Alcatel-Lucent	6
Chapter 1	OAW-AP85 Series Hardware Overview	7
	About the OAW-AP85 Series	7
	OAW-AP85 Series Operation	7
	Minimum Software Requirements	8
	Package Checklist	8
	Hardware Model Overview	9
	OAW-AP85 Series Front View	9
	OAW-AP85 Series Rear View	9
	OAW-AP85 Series Top View	10
	OAW-AP85TX Bottom View	10
	OAW-AP85FX/LX Bottom View	11
	LED Status Indicators	12
	Optional Accessories	13
Chapter 2	Outdoor Planning and Deployment Considerations	15
	Planning and Deployment Considerations	15
	Scale Requirements	15
	Identifying Known RF Absorbers/Reflectors/Interferences Sources	15
	RF Absorbers	15
	RF Reflectors	15
	RF Interference Sources	15
	Line of Sight (Radio Path Planning)	16
	Antenna Height	17
	Antenna Position and Orientation	18
	Radio Interference	19
	Weather Conditions	19
	Ethernet Cabling	19
	Grounding	19
Chapter 3	OAW-AP85 Series Installation	21
	Pre-Installation Network Setup	21
	Pre-Installation Checklist	21
	Access Point Setup	21
	1. Verifying Pre-Installation Connectivity	22
	2. Provisioning the AP	22
	3. Installing the OAW-AP85	22
	Mounting the OAW-AP85	23
	Positioning the OAW-AP85	27
	Connecting Required Cables	28
	Lightning Arrestor Installation	30
	Antenna Installation	30
	4. Verifying Post-Installation Connectivity	30
	5. Configuring the OAW-AP85	30
	AP Configuration	30

Appendix A	Understanding Antennas	31
	Alcatel-Lucent Antennas	31
	Understanding Wireless Antennas	31
	Omni-Directional vs. Directional Coverage	31
	Antenna Beamwidth, Pattern, and Gain Considerations	32
	Understanding Antenna Pattern Plots and Specifications	34
	Detachable Antenna Selection	35
	Detachable Outdoor Antenna Types	35
	Detachable Antenna Selection Tips	35
Appendix B	Product Specifications	41
	Mechanical (OAW-AP85TX, OAW-AP85FX, and OAW-AP85LX)	41
	Electrical	42
	OAW-AP85TX	42
	OAW-AP85FX	42
	OAW-AP85LX	42
	Maximum Power Draw	42
	Wireless LAN	43
	Safety and Regulatory Compliance	43
	Proper Disposal of Alcatel-Lucent Equipment	43
	Waste of Electrical and Electronic Equipment	44
	European Union RoHS	44
	China RoHS	44
Index		45

This preface includes the following information:

- An overview of the contents of this manual
- A list of related documentation for further reading
- Alcatel-Lucent support and service information

Guide Overview

- [Chapter 1, “OAW-AP85 Series Hardware Overview” on page 7](#) provides a detailed hardware overview of the three OAW-AP85 models: the OAW-AP85TX, the OAW-AP85FX, and the OAW-AP85LX.
- [Chapter 2, “Outdoor Planning and Deployment Considerations” on page 15](#) provides key questions to ask and items to consider when deploying an outdoor wireless network.
- [Chapter 3, “OAW-AP85 Series Installation” on page 21](#) describes the multi-step process for successful installation and deployment of an OAW-AP85.
- [Appendix A, “Understanding Antennas” on page 31](#) provides key tools that will help you understand Alcatel-Lucent antenna specifications.
- [Appendix B, “Product Specifications” on page 41](#) includes product technical specifications and safety and regulatory compliance information.

Related Documents

The following documents are referred to in this guide and are considered components of the complete documentation set needed for successful AP deployment and management:

- *AOS-W Quick Start Guide*
- *AOS-W User Guide*
- *Alcatel-Lucent OmniVista Mobility Manager User Guide*
- Alcatel-Lucent Outdoor Antenna Specifications

Contacting Alcatel-Lucent

Web Site Support	
Main Site	http://www.alcatel-lucent.com/wps/portal/enterprise
Support Site	https://service.esd.alcatel-lucent.com
Support Email	support@ind.alcatel.com

Telephone Support	
North America	1-800-995-2696
Latin America	1-877-919-9526
Europe	+33 (0) 38 855 6929
Asia Pacific	+65 6586 1555/1-818-878-4507
Worldwide	1-818-880-3500

About the OAW-AP85 Series

The OAW-AP85 Series consists of resilient, environmentally hardened, outdoor rated, dual-band IEEE 802.11a/b/g devices, which can be configured for deployment as a wireless access point, air monitor, mesh point, or mesh portal. This outdoor access point series is part of Alcatel-Lucent's comprehensive wireless network solution. The OAW-AP85 Series works only in conjunction with an Alcatel-Lucent WLAN Switch and each AP can be centrally managed, configured, and upgraded through the switch.

The OAW-AP85 Series consists of the following models:

- OAW-AP85TX (Ethernet)
- OAW-AP85FX (Multi-mode Fiber)
- OAW-AP85LX (Single-mode Fiber)

OAW-AP85 Series Operation

- Wireless access point (IEEE 802.11 a/b/g)
- Wireless air monitor (IEEE 802.11 a/b/g)
- Wireless access point with wireless backhaul support*
- Point-to-point wireless distribution system (WDS) bridge*
- Point-to-multi-point WDS bridge (host or slave)*
- Enterprise mesh point (MP; Mesh license required)*
- Enterprise mesh portal (MPP; Mesh license required)*
- Protocol-independent networking functionality
- IEEE 802.3af Power over Ethernet (PoE) compatible (OAW-AP85TX only)



NOTE

Items noted with an asterisk (*) require a secure enterprise mesh license. Contact your Alcatel-Lucent sales representative for a complete listing of available software licenses.



CAUTION

Alcatel-Lucent Access Points are required to be installed by a professional installer. The professional installer is responsible for ensuring that grounding is available and it meets applicable local and national electrical codes.



WARNING

Do not work on an AP and do not connect or disconnect cables during periods of lightning activity.

Minimum Software Requirements

The OAW-AP85 Series requires AOS-W 3.2.0 or later.

AOS-W software builds prior to version 3.2.0 do not support the OAW-AP85 Series. If your network currently runs on a software build prior to 3.2.0, you must upgrade the software on your master and local switches to 3.2.0 or later prior to installing an OAW-AP85 in your existing network.

Package Checklist

Included with all three OAW-AP85 models:

- Alcatel-Lucent OAW-AP85 outdoor access point (TX, FX, or LX model)
- OAW-AP85 wall/pole/mast mount kit (fixture with hardware)
- 8-foot DC outdoor rated power cable
- Weatherproof connector shell for RJ-45 terminated CAT 5 cable
 - LTW P/N LTWRJS-00PFFA-SL8001
- *Alcatel-Lucent OAW-AP85 Outdoor Access Point Installation Guide*

Included with the OAW-AP85FX/LX models only:

- 8-foot AC outdoor rated power cable (for FX/LX models only; US and EU options available)
- Fiber Optic Termination Kit
 - OAW-AP85FX: Tyco P/N 1828618-1
 - OAW-AP85LX: Tyco P/N 1828618-2



Inform your supplier if there are any incorrect, missing, or damaged parts. If possible, retain the carton, including the original packing materials. Use these materials to repack and return the unit to the supplier if needed.



Optional accessories are available for use with the OAW-AP85 and are sold separately. Refer to [Optional Accessories on page 13](#) for further details.

Hardware Model Overview

OAW-AP85 Series Front View

The front of the OAW-AP85 Series consists of LED status indicators (see [Figure 1](#)). For descriptions of the LEDs and their behavior, refer to [LED Status Indicators on page 12](#).

Figure 1 OAW-AP85 Series Front View

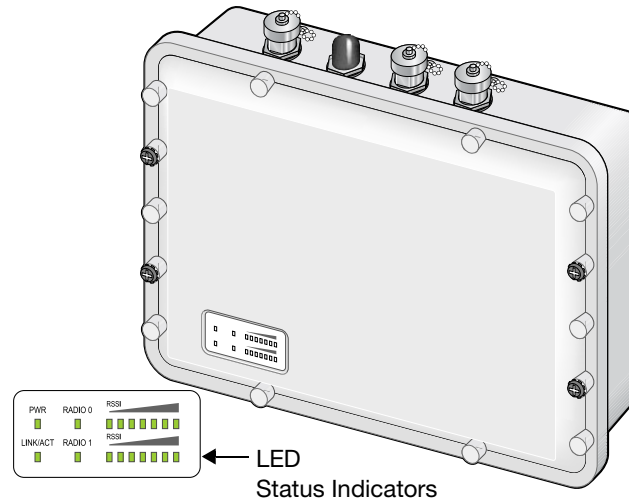

OAW-AP85 Series Rear View

The rear of the OAW-AP85 Series consists of four mounting holes (see [Figure 2](#)). Refer to [Chapter 3, “OAW-AP85 Series Installation” on page 21](#) for mounting and installation instructions.

Figure 2 OAW-AP85 Series Rear View

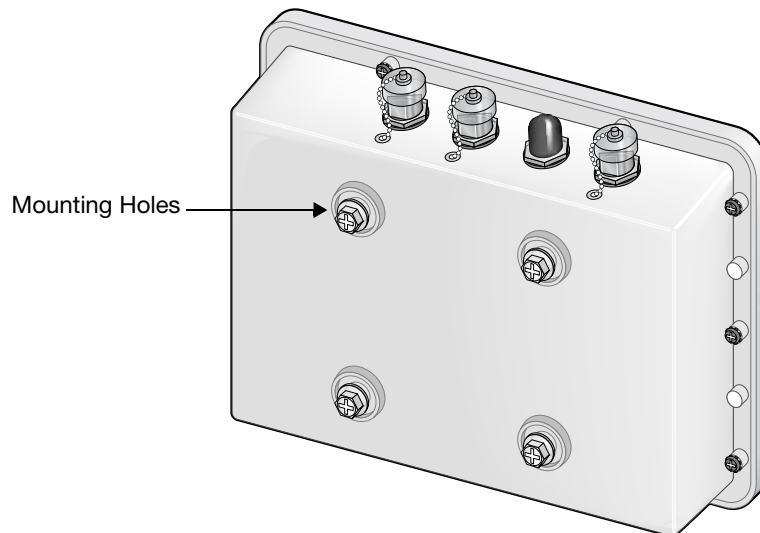

OAW-AP85 Series Top View

The top of the OAW-AP85 Series consists of four, female N-type antenna interfaces (see [Figure 3](#)).

Figure 3 OAW-AP85 Series Top View

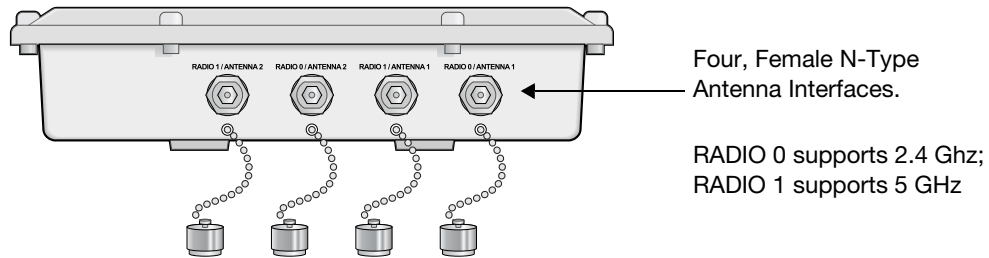

The OAW-AP85 Series requires the use of detachable, outdoor rated antennas. Select the correct antenna type to support the required frequency band (2.4 or 5 GHz) and the desired coverage pattern.

The four, female N-type antenna interfaces on the OAW-AP85 models are grouped into diversity pairs, one pair is marked as RADIO 0 and the other pair is marked as RADIO 1. RADIO 0 supports 2.4 GHz frequency band antennas and RADIO 1 supports 5 GHz frequency band antennas.

To select the correct antenna type for the deployment, download and read Alcatel-Lucent's outdoor antenna specifications: <http://www.arubanetworks.com/products/access-points/antennas.php>.

For further details, see [Appendix A, "Understanding Antennas"](#) on page 31.



An Alcatel-Lucent Lightning Arrestor, AP-LAR-1, must be installed on each antenna port for protection against lightning induced surges. Failure to use an AP-LAR-1 can void the warranty of an Alcatel-Lucent outdoor AP model and renders the AP susceptible to failure from lightning induced surges.

OAW-AP85TX Bottom View

The bottom of the OAW-AP85TX unit (see [Figure 5](#)) consists of the following ports and connections:

- **DC PWR 12 VDC, 2 A:** The AP is capable of accepting DC power in the range of 8 to 16 VDC. If the OAW-AP85TX is not connected to a PoE source, the AP must be powered via a DC power source. An outdoor rated, two-wire, 8-foot long DC power cable (wiring harness) is supplied with the unit. For proper installation instructions, see [DC and AC Power Cables on page 29](#).
- **LAN/POE 48 VDC, 350 mA:** Also known as a 10/100Base-T Fast Ethernet (RJ-45) port, which is IEEE 802.3 BaseT and 802.3u 100BaseTX compliant. This port supports IEEE 802.3af Power over Ethernet (PoE), accepting 48 VDC as a standards defined Powered Device (PD) from a Power Sourcing Equipment (PSE), such as a PoE midspan injector. The OAW-AP85TX also supports SPoE (Serial Power over Ethernet).

Figure 4 10/100Base-T Fast Ethernet (RJ-45) Port Pin-Out

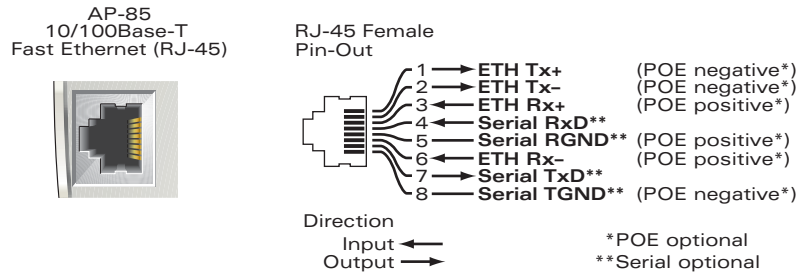

- **Grounding Point:** It is important that the OAW-AP85TX be properly grounded and a grounding point is provided on the bottom of the OAW-AP85TX model. A professional installer should ensure that grounding is available and meets applicable local and national electrical codes.

Figure 5 OAW-AP85TX Bottom View

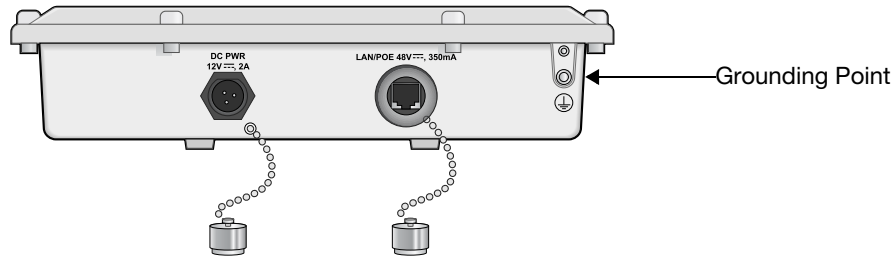

OAW-AP85FX/LX Bottom View

The bottom of the OAW-AP85FX/LX unit (see [Figure 5](#)) consists of the following ports and connections:

- **DC PWR 12 VDC, 2 A:** The AP is capable of accepting DC power in the range of 8 to 16 VDC. If the OAW-AP85FX/LX is not connected to an AC power source, the AP must be powered via a DC power source. An outdoor rated, two-wire, 8-foot long DC power cable (wiring harness) is supplied with the unit. For proper installation instructions, see [DC and AC Power Cables on page 29](#).
- **LAN - OPTICAL:**
 - **OAW-AP85FX:** This model consists of a 100BASE-FX data uplink port for multi-mode, dual-fiber network connectivity. A **multi-mode**, fiber patch cable with a duplex LC connector is required for use. The cable is not included and must be purchased separately.
 - **OAW-AP85LX:** This model consists of a 100BASE-LX data uplink port for single-mode, dual-fiber network connectivity. A **single-mode**, fiber patch cable with a duplex LC connector is required for use. The cable is not included and must be purchased separately.
- **CONSOLE:** A serial console port is provided for connection to a terminal, allowing for direct local management.

Figure 6 Serial Console Port Pin-Out

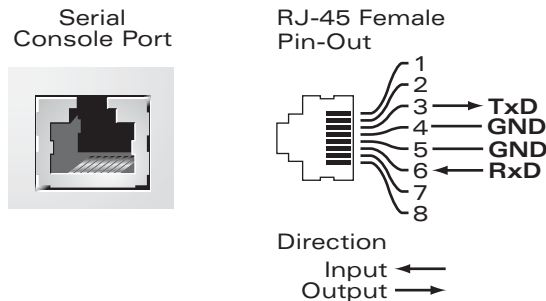

Communication settings for the serial console port are indicated in [Table 1](#).

Table 1 Console Terminal Settings

Baud Rate	Data Bits	Parity	Stop Bits	Flow Control
9600	8	None	1	None

- AC PWR 90-228 V~, 500 mA: The AP is capable of accepting AC power at the limits specified on the unit. If the OAW-AP85FX/LX is not connected to a DC power source, the AP must be powered via an AC power source. An outdoor rated, three-wire, 8-foot long AC power cable (wiring harness) is supplied with the unit. For proper installation instructions, see .
- Grounding Point: It is important that the OAW-AP85FX/LX be properly grounded and a grounding point is provided on the bottom of the OAW-AP85FX/LX model. A professional installer should ensure that grounding is available and meets applicable local and national electrical codes.

Figure 7 OAW-AP85FX/LX Bottom View

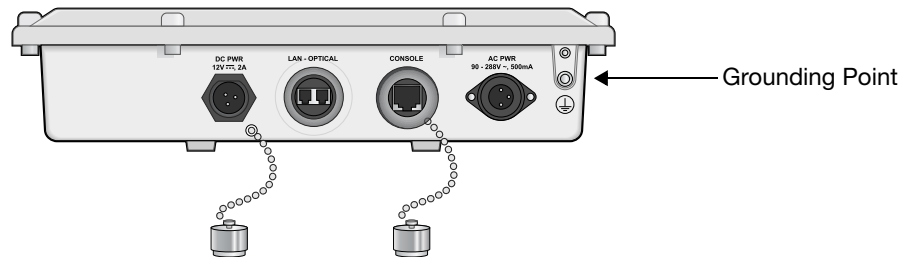

LED Status Indicators

All OAW-AP85 models include visual indicators for power, link, and radio status. Additionally, a seven LED array is provided for each radio, which indicates received signal strength (RSSI).



The RSSI LED indicators represent varying degrees in the RSSI level. The absence of a signal is indicated by no LED response, while full signal strength is indicated when all seven LEDs are active and lit.

[Table 2](#) provides an LED system breakdown for the OAW-AP85 outdoor access points.

Table 2 OAW-AP85 LED Status Indicators

LED	Function	Indicator	Status
PWR	AP Power/Ready Status	Off	No power to AP
		Flashing	Device booting, not ready
		On	Device ready
LINK/ACT (applicable to the OAW-AP85TX only)	LAN/Network Link Status	Off	Ethernet link unavailable
		On (Yellow)	10 Mbs Ethernet link negotiated
		On (Green)	100 Mbs Ethernet link negotiated
		Blinking	Traffic on Ethernet link

Table 2 OAW-AP85 LED Status Indicators

LED	Function	Indicator	Status
LINK/ACT (applicable to the OAW-AP85FX/LX models only)	LAN/Network Link Status	Off	Ethernet link unavailable
		On (Green)	100 Mbs Ethernet link negotiated
		Blinking	Traffic on Ethernet link
RADIO 0	Radio 0 Status	Off	Radio 0 disabled
		On (Yellow)	Radio 0 enabled in WDS mode
		On (Green)	Radio 0 enabled in WLAN mode
RADIO 1	Radio 1 Status	Off	Radio 1 disabled
		On (Yellow)	Radio 1 enabled in WDS mode
		On (Green)	Radio 1 enabled in WLAN mode
RSSI (Radio 0)	RSSI Level for Radio 0	Off	RSSI disabled/no signal
		7 Step Progressive Bars 3/6/9/12/15/21/27 dB RSSI	Each bar represents a progressive increase in signal strength, with 7 bars representing maximum signal strength (100%). Minimum data rate: Two lit LEDs Maximum data rate: Six lit LEDs
RSSI (Radio 1)	RSSI Level for Radio 1	Off	RSSI disabled/no signal
		7 Step Progressive Bars 3/6/9/12/15/21/27 dB RSSI	Each bar represents a progressive increase in signal strength, with 7 bars representing maximum signal strength (100%). Minimum data rate: Two lit LEDs Maximum data rate: Six lit LEDs

Optional Accessories

The following items are available for use with OAW-AP85 outdoor access points and are sold separately. Contact your Alcatel-Lucent sales representative for details and assistance.

- Alcatel-Lucent 85 Field Replaceable Mount Kit
- Alcatel-Lucent 85 Streetlight Power Tap Adaptor (8 ft)
- Alcatel-Lucent 85 AC Power Provisioning Cable (3 ft; indoor rated)
- Alcatel-Lucent 85 Antenna Mount Bracket
- Alcatel-Lucent 85 AC Power Cable (8 ft)
- Alcatel-Lucent 85 AC Power Cable (40 ft)
- Alcatel-Lucent 85 DC Power Cable (8 ft)
- Alcatel-Lucent Lightning Arrestor



AC power cables are available for use with the OAW-AP85FX/LX models only.

Planning and Deployment Considerations

Prior to deploying an outdoor wireless network, the environment must be evaluated to plan for a successful Alcatel-Lucent WLAN deployment. Successfully evaluating the environment enables the proper selection of Alcatel-Lucent APs and antennas and assists in the determination of their placement for optimal RF coverage. This process is considered WLAN or RF planning and Alcatel-Lucent's system engineers can assist in the outdoor planning process.

Scale Requirements

The potentially immense scale of outdoor deployments requires consideration of factors that may not be as important in a typical indoor deployment:

- **Range (distance):** Range or distance between APs must be taken into account during the planning phase. Available AP mounting locations are often far less flexible in an outdoor environment. Regardless of these outdoor restrictions, the desired goal is to achieve results similar to an indoor deployment: a “dense” RF deployment that supports advanced Alcatel-Lucent features, such as ARM, efficient client roaming, and failover.
- **Elevation:** Proper consideration and planning for elevation differences between APs (AP to AP) and AP to Client can be *critical* to success. To plan for these differences in elevation, it is important to understand the 3D coverage pattern provided by the antennas that will be deployed in the environment.
- **Non-Fixed Considerations:** The RF environment might change on a day to day basis. Keep non-fixed items, such as shipping containers, vehicles, and future building construction, in mind when planning for an outdoor deployment.

Identifying Known RF Absorbers/Reflectors/Interferences Sources

Identifying known RF absorbers/reflectors/interference sources while out in the field during the installation phase is critical. Even though outdoor environments consist of fewer RF absorbers/reflectors/interference sources compared to indoor environments, ensure that these sources are identified and taken into consideration when installing and mounting an AP to its fixed outdoor location.

RF Absorbers

- Cement/Concrete
- Natural Items: Trees/vegetation
- Brick

RF Reflectors

- **Metal Objects:** Roof-installed air-conditioning equipment, chain link fences (depending on aperture size), other wire fences, or water pipes

RF Interference Sources

- Other 802.11a/b/g or broadband access equipment operating nearby

- Industrial RF welding equipment or other Industrial, Scientific and Medical (ISM) equipment that utilizes RF to heat or alter the physical properties of materials
- Military, Commercial Aviation or Weather Radar Systems

Line of Sight (Radio Path Planning)

OAW-AP85 Series access points are capable of performing as one of the following:

- Point-to-point wireless distribution system (WDS) bridge
- Point-to-multi-point WDS bridge
- Enterprise mesh point (MP)
- Enterprise mesh portal (MPP)



To configure the OAW-AP85 as a mesh point or mesh portal, you must install a mesh software license on a WLAN Switch as a software license key. Contact your sales account manager or authorized reseller to obtain the software license. There are several mesh software licenses available that support different maximum number of APs. The licenses are cumulative; each additional license installed increases the number of APs (mesh nodes) supported by the WLAN Switch.

A wireless bridge or mesh link requires a “radio line of sight” between the two antennas for optimum performance. The concept of radio line of sight involves the area along a link through which the bulk of the radio signal power travels. This area is known as the first Fresnel Zone of the radio link. For a radio link, no object (including the ground) must intrude within 60% of the first Fresnel Zone.

Figure 8 illustrates the concept of a good radio line of sight.

Figure 8 *Line of Sight*

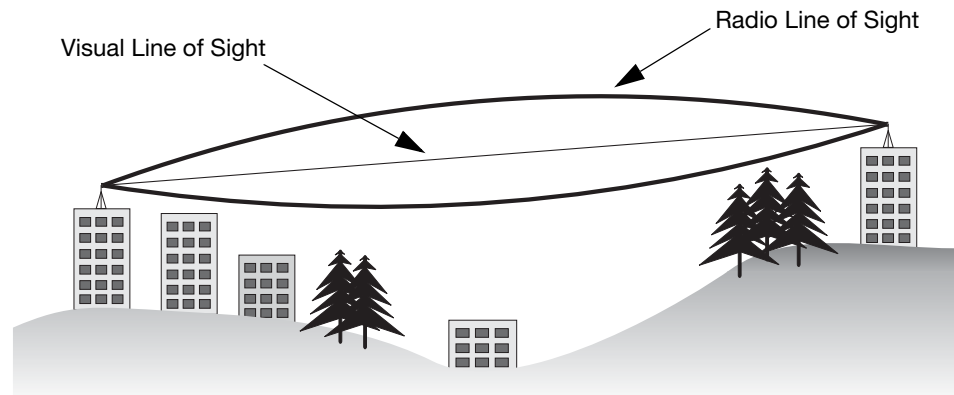

If there are obstacles in the radio path, there may still be a radio link but the quality and strength of the signal will be affected. Calculating the maximum clearance from objects on a path is important as it directly affects the decision on antenna placement and height. It is especially critical for long-distance links, where the radio signal could easily be lost.

When planning the radio path for a wireless bridge or mesh link, consider these factors:

- Avoid any partial line of sight between the antennas.
- Be cautious of trees or other foliage that may be near the path, or may grow and obstruct the path.
- Be sure there is enough clearance from buildings and that no building construction may eventually block the path.
- For very long distance links, the curvature of the earth (20 cm per km) may need to be considered in the calculation of relative heights.

- Check the topology of the land between the antennas using topographical maps, aerial photos, or even satellite image data (software packages are available that may include this information for your area).
- Avoid a path that may incur temporary blockage due to the movement of cars, trains, or aircraft.

Antenna Height

A reliable wireless bridge or mesh link is usually best achieved by mounting the antennas at each end high enough for a clear radio line of sight between them. The minimum height required depends on the distance of the link, obstacles that may be in the path, topology of the terrain, and the curvature of the earth (for links over 3 miles).

For long-distance links, the AP may have to be mounted on masts or poles that are tall enough to attain the minimum required clearance. Use the following table to estimate the required minimum clearance above the ground or path obstruction (for 5 GHz bridge links).

Table 3 *Antenna Minimum Height and Clearance Requirements*

Total Link Distance	Max Clearance for 60% of First Fresnel Zone at 5.8 GHz	Approximate Clearance for Earth Curvature	Total Clearance Required at Mid-point of Link
0.25 mile (0.402 km)	4.6 ft (1.4 m)	0.007 ft (0.002 m)	4.6 ft (1.4 m)
0.5 mile (0.805 km)	6.2 ft (1.9 m)	0.03 ft (0.010 m)	6.2 ft (1.9 m)
1 mile (1.6 km)	8.9 ft (2.7 m)	0.13 ft (0.04 m)	8.9 ft (2.7 m)
2 miles (3.2 km)	12.5 ft (3.8 m)	0.5 ft (0.15 m)	13.1 ft (4.0 m)
3 miles (4.8 km)	15.4 ft (4.7 m)	1.0 ft (0.3 m)	16.4 ft (5.0 m)
4 miles (6.4 km)	17.7 ft (5.4 m)	2.0 ft (0.6 m)	19.7 ft (6.0 m)
5 miles (8 km)	20 ft (6.1 m)	3.0 ft (0.9 m)	23 ft (7.0 m)
7 miles (11.3 km)	23.6 ft (7.2 m)	6.2 ft (1.9 m)	30 ft (9.1 m)
9 miles (14.5 km)	27 ft (8.2 m)	10.2 ft (3.1 m)	37 ft (11.3 m)
12 miles (19.3 km)	30.8 ft (9.4 m)	18.0 ft (5.5 m)	49 ft (14.9 m)
15 miles (24.1 km)	34.4 ft (10.5 m)	28.0 ft (8.5 m)	62.7 ft (19.1 m)



To avoid any obstruction along the path, the height of the object must be added to the minimum clearance required for a clear radio line of sight. Consider the following simple example, illustrated in the figure below.

Figure 9 Antenna Height and Line of Sight

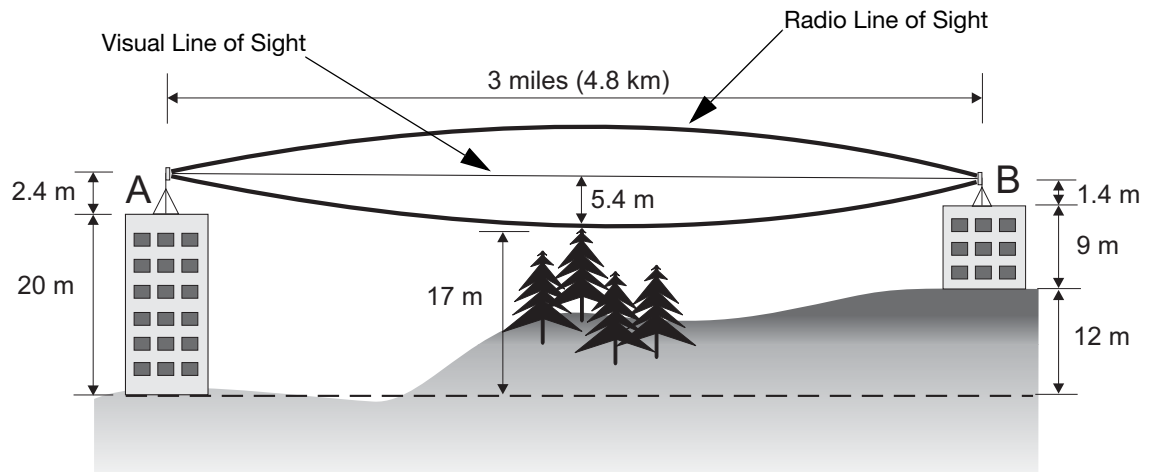

A wireless bridge or mesh link is deployed to connect building A to building B, which is located three miles (4.8 km) away. Mid-way between the two buildings is a small tree-covered hill. From the above table it can be seen that for a three-mile link, the object clearance required at the mid-point is 5.3 m (17.4 ft). The tree tops on the hill are at an elevation of 17 m (56 ft), so the antennas at each end of the link need to be at least 22.3 m (73 ft) high. Building A is six stories high, or 20 m (66 ft), so a 2.3 m (7.5 ft) mast or pole must be constructed on its roof to achieve the required antenna height. Building B is only three stories high, or 9 m (30 ft), but is located at an elevation that is 12 m (39 ft) higher than building A. To mount an antenna at the required height on building B, a mast or pole of 1.3 m (4.3 ft) is needed.



CAUTION

Never construct a radio mast, pole, or tower near overhead power lines.



NOTE

Local regulations may limit or prevent construction of a high radio mast or tower. If your wireless bridge or mesh link requires a high radio mast or tower, consult a professional contractor for advice.

Antenna Position and Orientation

Once the required antenna height has been determined, other factors affecting the precise position of the wireless bridge or mesh link must be considered:

- Be sure there are no other radio antennas within 2 m (6 ft) of the wireless bridge or mesh link. These include other WiFi radio antennas.
- Place the wireless bridge or mesh link away from power and telephone lines.
- Avoid placing the wireless bridge or mesh link too close to any metallic reflective surfaces, such as roof-installed air-conditioning equipment, tinted windows, wire fences, or water pipes. Ensure that there is at least 5 feet clearance from such objects.
- The wireless bridge or mesh link antennas at both ends of the link must be positioned with the same polarization direction, either horizontal or vertical. Proper alignment helps to maximize throughput.

Radio Interference

The avoidance of radio interference is an important part of wireless link planning. Interference is caused by other radio transmissions using the same or an adjacent channel frequency. You should first scan your proposed site using a spectrum analyzer to determine if there are any strong radio signals using the 802.11a/b/g channel frequencies. Always use a channel frequency that is furthest away from another signal.

If radio interference is still a problem with your wireless bridge or mesh link, changing the antenna direction may improve the situation.

Weather Conditions

When planning wireless bridge or mesh links, you must take into account any extreme weather conditions that are known to affect your location. Consider these factors:

- **Temperature:** The wireless bridge or mesh link is tested for normal operation in temperatures from -40°C to 70°C . Operating in temperatures outside of this range may cause the unit to fail.
- **Wind Velocity:** The wireless bridge or mesh link can operate in winds up to 120 km/h . You must consider the known maximum wind velocity and direction at the site and be sure that any supporting structure, such as a pole, mast, or tower, is built to withstand this force.
- **Lightning:** Rain: The wireless bridge or mesh link is weatherproofed against rain. However, it is



An Alcatel-Lucent Lightning Arrestor, AP-LAR-1, must be installed on each antenna port for protection against lightning induced surges. Failure to use an AP-LAR-1 can void the warranty of an Alcatel-Lucent outdoor AP model and renders the AP susceptible to failure from lightning induced surges.

recommended to apply weatherproof sealing tape around the Ethernet port and antenna connectors for extra protection. If moisture enters a connector, it may cause a degradation in performance or even a complete failure of the link.

- **Snow and Ice:** Falling snow, like rain, has no significant effect on the radio signal. However, a buildup of snow or ice on antennas may cause the link to fail. In this case, the snow or ice has to be cleared from the antennas to restore operation of the link.

Ethernet Cabling

When a suitable antenna location has been determined, you must plan a cable route from the wireless bridge or mesh link outdoors to a suitable power and/or network source.

Consider these points:

- The Ethernet cable length should never be longer than 90 m (295 ft).
- Determine a building entry point for the cable (if applicable).
- Determine if conduits, bracing, or other structures are required for safety or protection of the cable.
- For lightning protection at the power injector end of the cable, consider using a lightning arrestor immediately before the cable enters the building.

Grounding

It is important that the wireless bridge or mesh link, cables, and any supporting structures are properly grounded. Each OAW-AP85 Series access point includes a grounding screw for attaching a ground wire. Be sure that grounding is available and that it meets local and national electrical codes.

Pre-Installation Network Setup

Once WLAN planning is complete and the appropriate products and their placement have been determined, installation and initial setup of the Alcatel-Lucent WLAN Switch(es) is required prior to deployment of Alcatel-Lucent Outdoor Access Points.

For initial setup of the WLAN Switch, refer to the *AOS-W Quick Start Guide* for the software version installed on your switch.

Pre-Installation Checklist

Before installing your OAW-AP85, ensure that the following requirements are met:

Table 4 OAW-AP85 Pre-Installation Checklist

OAW-AP85TX	OAW-AP85FX/LX
<ul style="list-style-type: none"> ● Fast Ethernet (FE) cable of required length ● IEEE 802.3af compliant PoE source (Alcatel-Lucent WLAN Switch or Midspan device) or DC power source ● Alcatel-Lucent WLAN Switch configured and installed on the network ● Layer 2/3 network connectivity to your OAW-AP85 ● One of the following network services: <ol style="list-style-type: none"> 1. Alcatel-Lucent Discovery Protocol (ADP) 2. DNS server with an “A” record 3. DHCP Server with vendor specific options 	<ul style="list-style-type: none"> ● Fiber patch cable of required length: <ol style="list-style-type: none"> 1. Single-mode fiber patch cable for the OAW-AP85LX 2. Multi-mode fiber patch cable for the OAW-AP85FX ● AC or DC power source ● Alcatel-Lucent WLAN Switch configured and installed on the network ● Layer 2/3 network connectivity to your OAW-AP85 ● One of the following network services: <ol style="list-style-type: none"> 1. Alcatel-Lucent Discovery Protocol (ADP) 2. DNS server with an “A” record 3. DHCP Server with vendor specific options

Access Point Setup



It is important that you follow the guidelines in the previous section, [Pre-Installation Network Setup](#) on page 21, prior to attempting to setup and install an OAW-AP85.

Successful setup of an OAW-AP85 is a multi-step process, which must be followed in the sequence listed:

1. Verifying Pre-Installation Connectivity
2. Provisioning the OAW-AP85
3. Installing the OAW-AP85
4. Verifying Post-Installation Connectivity
5. Configuring the OAW-AP85



Alcatel-Lucent, in compliance with governmental requirements, has designed the OAW-AP85 such that only authorized network administrators can change configuration settings. For more information on AP configuration, refer to the *AOS-W Quick Start Guide* and *AOS-W User Guide*.



Access Points are radio transmission devices and as such are subject to governmental regulation. Network administrators responsible for the configuration and operation of Access Points must comply with local broadcast regulations. Specifically, Access Points must use channel assignments appropriate to the location in which the Access Point will be used.

1. Verifying Pre-Installation Connectivity

Before you install APs in a network environment, ensure that the APs will be able to locate and connect to the WLAN Switch when powered on.

Specifically, you must ensure the following:

- When connected to the network, each AP is assigned a valid IP address.
- APs are able to locate the WLAN Switch (WLAN SwitchDiscovery).

Refer to the *AOS-W Quick Start Guide* for instructions on locating and connecting to the WLAN Switch.

2. Provisioning the AP

Provisioning parameters are unique to each AP. These local AP parameters are initially configured on the WLAN Switch which are then pushed out to the AP and stored on the AP itself. Alcatel-Lucent recommends that provisioning settings be configured via the AOS-W Web UI only. Refer to the *AOS-W User Guide* for complete details.



If the OAW-AP85 is to be deployed in a mesh networking environment, the OAW-AP85 must be provisioned as a mesh portal or a mesh point prior to deployment.

3. Installing the OAW-AP85



RF Radiation Exposure Statement: This equipment complies with FCC RF radiation exposure limits. This equipment should be installed and operated with a minimum distance of 7.9 inches (20 cm) between the radiator and your body for 2.4 GHz and 5 GHz operations. This transmitter must not be co-located or operating in conjunction with any other antenna or transmitter.



Alcatel-Lucent Access Points, AP-LAR-1 lightning arrestors, and cable termination kits are required to be installed by a professional installer. The professional installer is responsible for ensuring that grounding is available and it meets applicable local and national electrical codes.



Do not work on an AP and do not connect or disconnect cables during periods of lightning activity.

Mounting the OAW-AP85

Preparing the OAW-AP85 for Installation

1. Install the four included mounting bolts (M8 bolts with captive flat washer) into the four mounting holes on the rear of the OAW-AP85 (see [Figure 10](#)). Leave approximately two to three threads showing on the mounting bolts.

Figure 10 *Installing the Mounting Bolts*

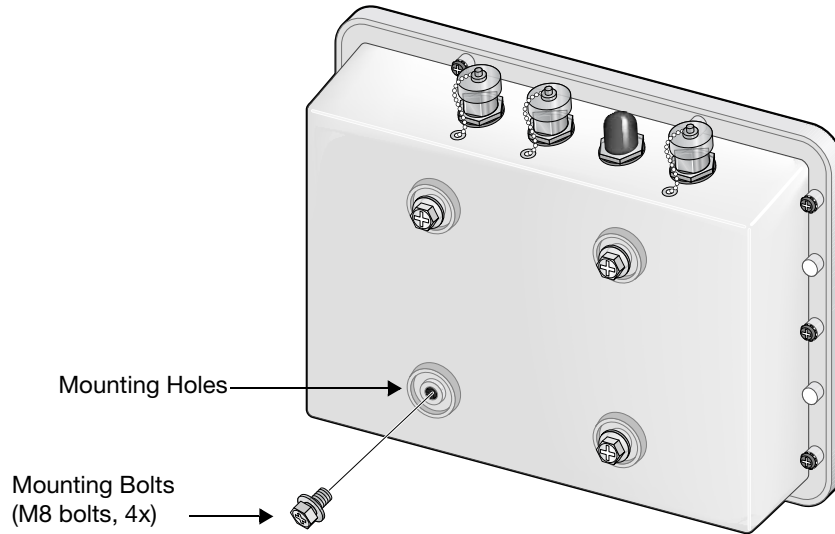

Wall Mounting the OAW-AP85

To wall mount an OAW-AP85:

1. Secure the mounting plate to a flat wall using the appropriate screws and anchors for your mounting application (see [Figure 11](#)).



NOTE

Wall mount hardware is not included with the mounting plate and must be purchased separately for your mounting application. The mounting plate accepts the following screw/bolt sizes: M4, M5, SAE #8, and SAE #10.

Figure 11 *Attaching the Mounting Plate*

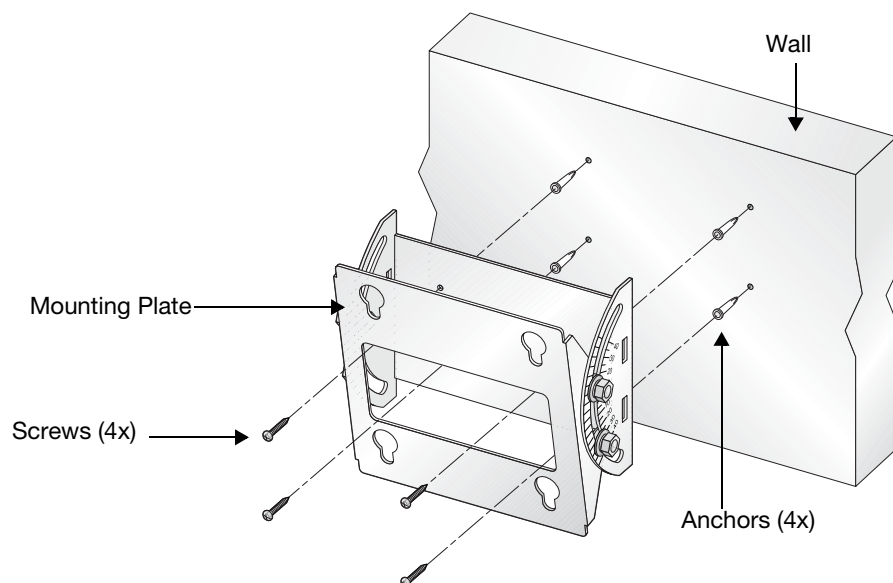

2. Seat the OAW-AP85 into the four keyholes on the mounting plate and tighten down the four mounting bolts (M8 bolts) to secure the OAW-AP85 in place (see [Figure 12](#)). The mounting plate should rest between the captive flat washer on each of the mounting bolts and the rear of the OAW-AP85.



The positioning of the keyholes on the mounting plate supports horizontal or vertical mounting of the OAW-AP85, which is achieved by rotating the device by 90 degrees and securing it to the mounting plate.

Figure 12 Wall Mounting the OAW-AP85

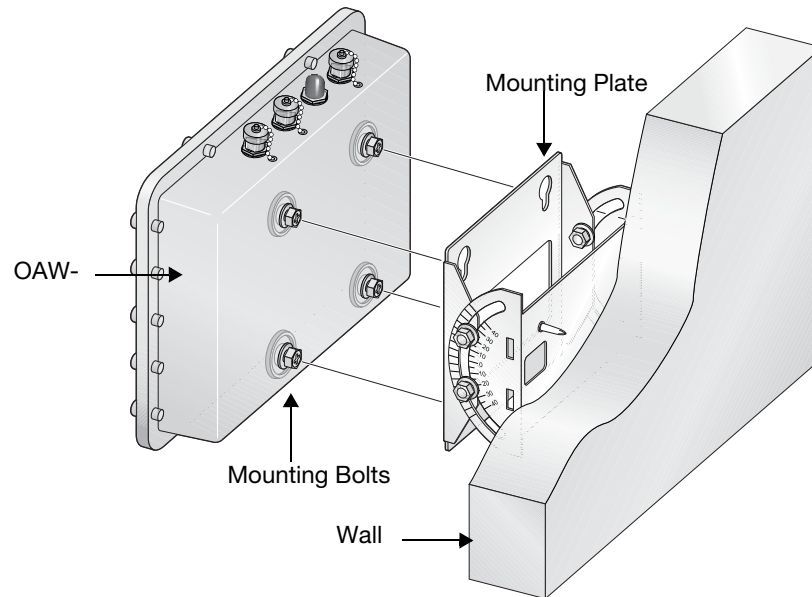

Pole Mounting the OAW-AP85 (1.5" to 3.5" Diameter)

To mount an OAW-AP85 to a pole with a diameter of 1.5" to 3.5":

1. Slide the long T-bolt through the opening in the mounting bracket (see [Figure 13](#)).
2. Attach the included retaining clip to the T-bolt (see [Figure 13](#)).
3. Screw the included nut onto the end of the T-bolt (see [Figure 13](#)).
4. Secure the mounting plate to the mounting bracket using the four included phillips head screws (see [Figure 13](#)).

Figure 13 Assembling the Pole Mounting Bracket

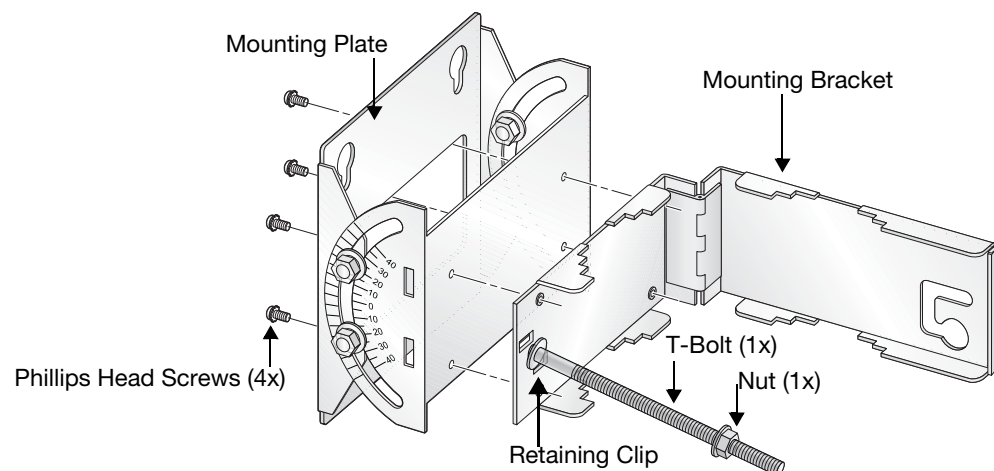

5. Wrap the pole mounting bracket around a 1.5" to 3.5" diameter pole and secure the bracket in place (see [Figure 14](#)).
 - a. Wrap the pole mounting bracket around the pole.
 - b. Slip the end of the T-bolt with nut through the opening in the pole mounting bracket.
 - c. Maneuver the T-bolt to the top slot in the pole mounting bracket and tighten down the nut. Ensure that the nut is tightly secured and that the bracket cannot move. It must be secure to support the weight of the OAW-AP85.

Figure 14 *Securing the Pole Mounting Bracket*

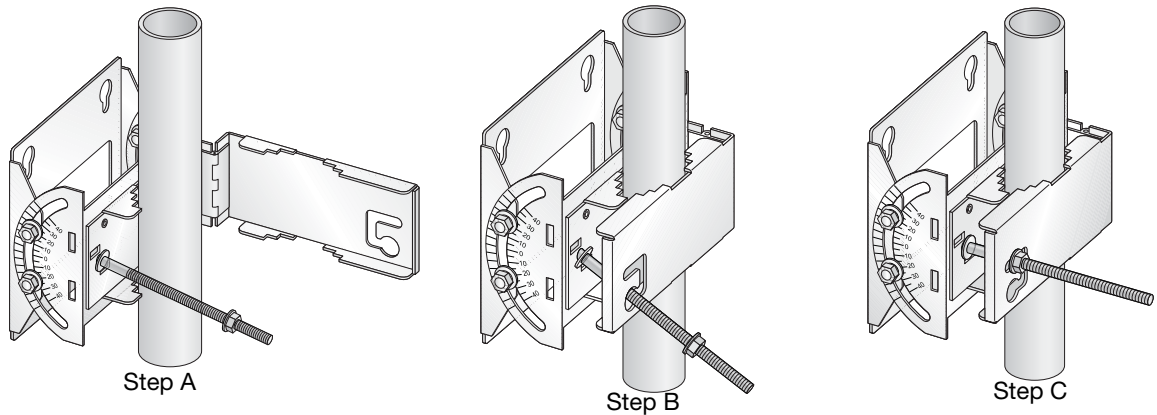

6. Seat the OAW-AP85 into the four keyholes on the mounting plate and tighten down the four mounting bolts (M8 bolts) to secure the OAW-AP85 in place (see [Figure 15](#)). The mounting plate should rest between the captive flat washer on each of the mounting bolts and the rear of the OAW-AP85.



The pole mounting bracket can be secured to a horizontal or vertical pole. The positioning of the keyholes on the bracket supports horizontal or vertical mounting of the OAW-AP85 on either pole type, which is achieved by rotating the device by 90 degrees and securing it to the bracket. Refer to [Figure 15](#) and [Figure 16](#) for details.

Figure 15 *Vertical Pole Mount Position (1.5" to 3.5" Diameter)*

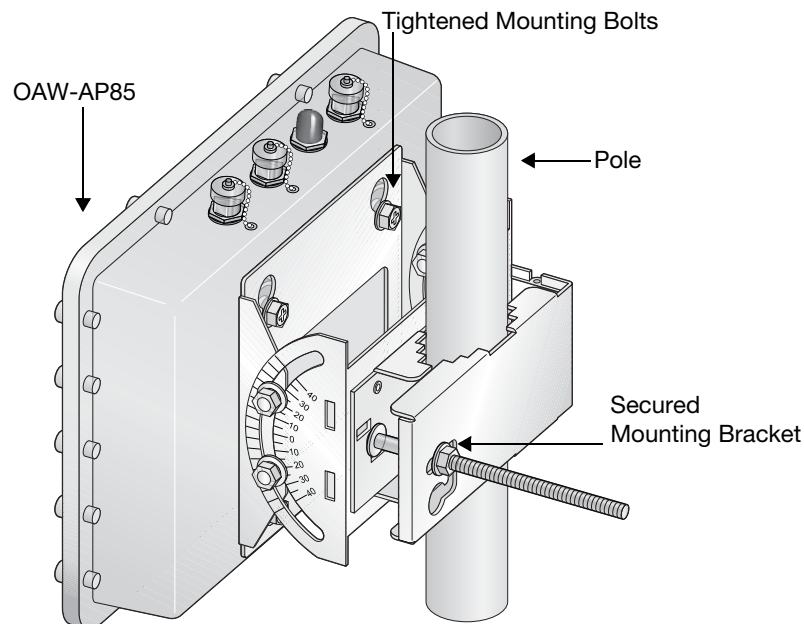
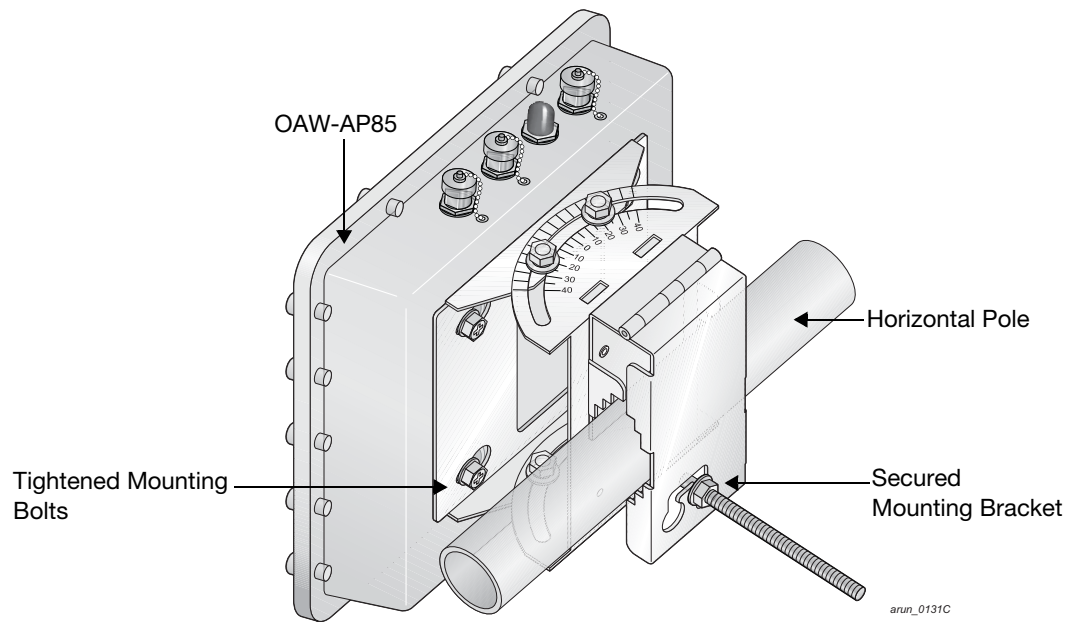

Figure 16 Horizontal Pole Mount Position (1.5" to 3.5" Diameter)



Pole Mounting the OAW-AP85 (>3.5" Diameter)

To mount an OAW-AP85 to a pole with a diameter greater than 3.5”:

1. Attach the mounting plate to the pole using outdoor rated straps (see [Figure 17](#)). Outdoor rated straps are not included with the unit and must be purchased separately.
2. Seat the OAW-AP85 into the four keyholes on the mounting plate and tighten down the four mounting bolts (M8 bolts) to secure the OAW-AP85 in place (see [Figure 17](#)). The mounting plate should rest between the captive flat washer on each of the mounting bolts and the rear of the OAW-AP85.



The mounting plate can be secured to a horizontal or vertical pole. The positioning of the keyholes on the mounting plate supports horizontal or vertical mounting of the OAW-AP85 on either pole type, which is achieved by rotating the device by 90 degrees and securing it to the mounting plate.

Figure 17 Pole Mounting the OAW-AP85 (>3.5" Diameter)

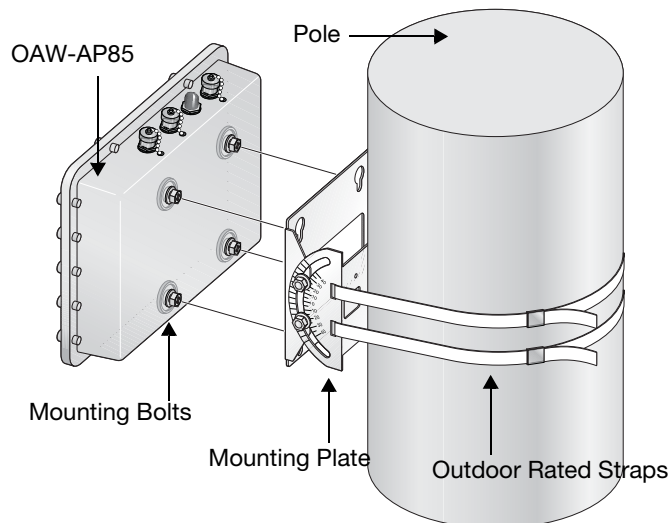

Positioning the OAW-AP85

To adjust the angle of an OAW-AP85 on a vertical pole:

1. Loosen the four M8 bolts on the side of the mounting plate and rotate the AP to the desired angle and tighten down the M8 bolts (see [Figure 18](#)).

Figure 18 Positioning the OAW-AP85 on a Vertical Pole

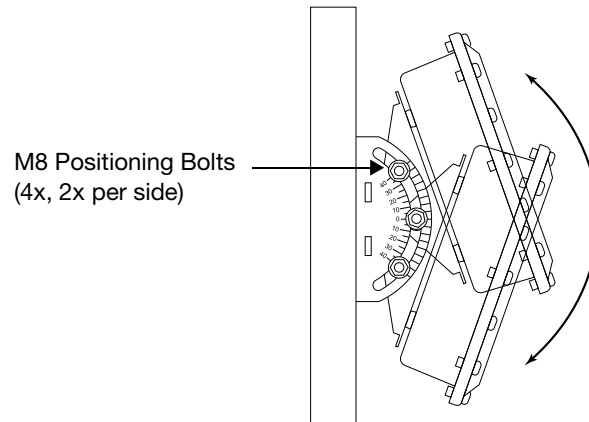

To adjust the angle of an OAW-AP85 on a horizontal pole:

1. Rotate the entire mounting bracket to the desired angle and tighten the bracket into place (see [Figure 19](#)).

Figure 19 Positioning the OAW-AP85 on a Horizontal Pole

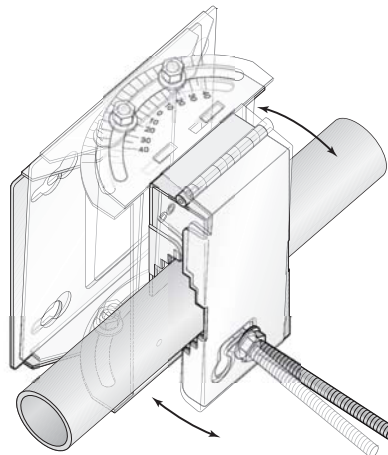
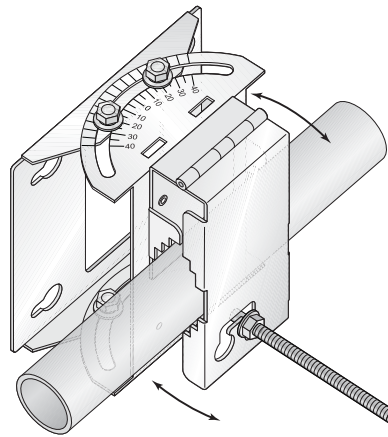

arup_0131E

Connecting Required Cables

RJ-45 CAT 5 Cable

To weatherproof and connect an RJ-45 terminated CAT 5E or better cable to an OAW-AP85 (see [Figure 20](#)), perform the following using the contents in the included kit that ships with your unit:



The cable is not included and must be purchased separately. Purchase a suitable UV resistant, outdoor rated, CAT 5E or better RJ-45 cable for use with the OAW-AP85.

1. Slide the cap over the terminated cable.
2. Slide the rubber grommet over the terminated cable.
3. Slide the connector shell over the terminated cable.
4. Slide the washer over the terminated cable.
5. Insert the rubber grommet into the top of the connector shell until the top surface of the grommet is flush with the top edge of the connector shell.
6. Connect the terminated cable to the proper port: LAN/POE port on the OAW-AP85TX model or the CONSOLE port on the OAW-AP85FX/LX models.
7. Screw the connector shell onto the interface on the OAW-AP85.
8. Screw the cap onto the connector shell.

Figure 20 Weatherproofing and Connecting an RJ-45 Terminated CAT 5 Cable

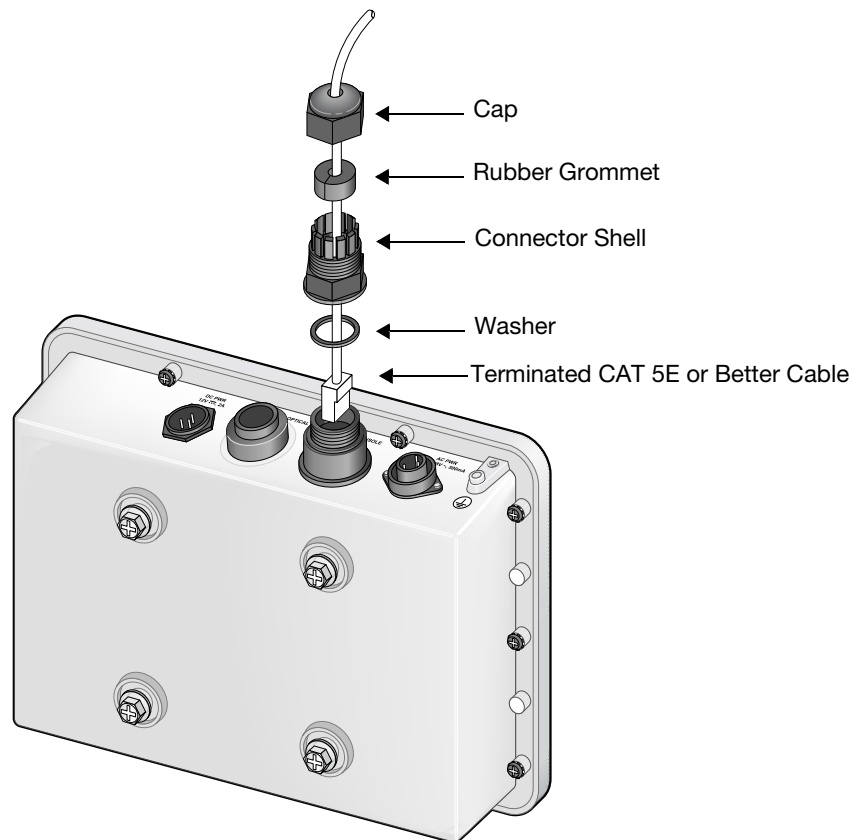

DC and AC Power Cables

To connect the power cables (wiring harnesses):

1. Screw the two-wire, 8-foot long DC power cable (wiring harness) to the DC interface on the OAW-AP85TX, OAW-AP85FX, or OAW-AP85LX model.
2. Screw the three-wire, 8-foot long AC power cable (wiring harness) to the AC interface on the OAW-AP85FX or OAW-AP85LX models only.



Disconnect the AC mains before handling the AC power cable and connecting it to the OAW-AP85.

Figure 21 *Connecting Power*

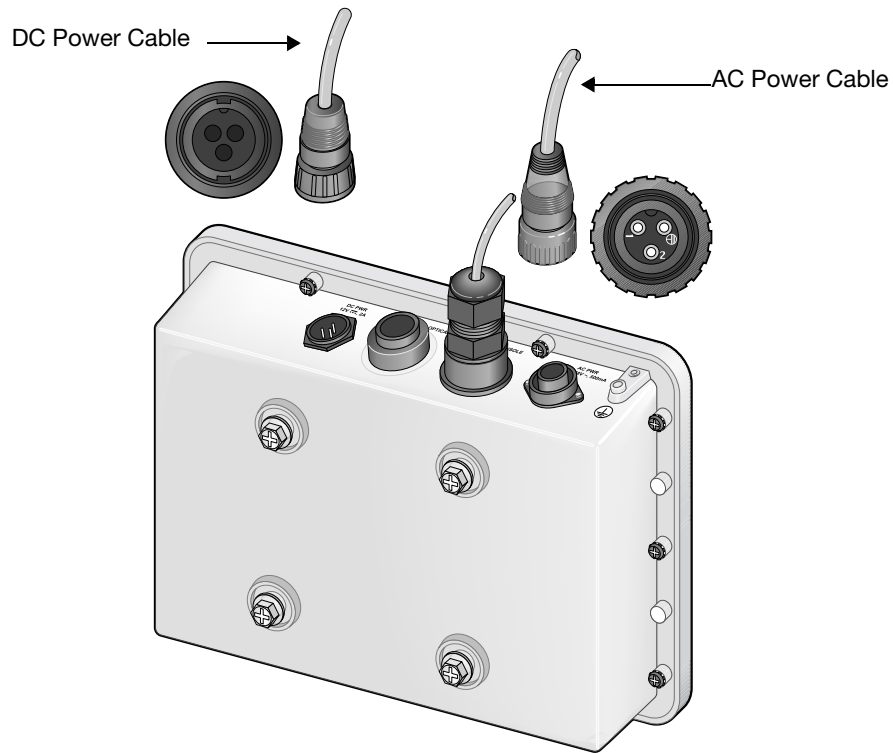

arun_0128B

Table 5 *AC and DC Power Cable Descriptions*

Cable Type	Wire Color	Assignment
DC Power Cable	Red	+12V
	Black	Ground
AC Power Cable: United States (US)	Black	Line
	White	Neutral
	Green	Ground
AC Power Cable: Europe (EU)	Brown	Line
	Blue	Neutral
	Green/Yellow	Ground

Fiber Optic Cable

To utilize the fiber optic termination kit that ships with the OAW-AP85FX/LX models:

1. Follow the instructions in the included Tyco document: Instruction Sheet 408-10079.



Fiber optic cables are not included and must be purchased separately. Purchase a suitable UV resistant, outdoor rated, multi-mode fiber optic cable for use with the OAW-AP85FX and a single-mode fiber optic cable for use with the OAW-AP85LX.

Lightning Arrestor Installation

Refer to the instructions that ship with the Alcatel-Lucent lightning arrestor (AP-LAR-1).

Antenna Installation

Refer to the instructions that ship with your Alcatel-Lucent outdoor rated antenna.

4. Verifying Post-Installation Connectivity

The integrated LEDs on the OAW-AP85 can be used after installation to verify that the AP is receiving power, is initializing successfully, and that wireless connectivity is occurring (see [LED Status Indicators on page 12](#)). Refer to the *AOS-W Quick Start Guide* for further details on verifying post-installation network connectivity.

5. Configuring the OAW-AP85

AP Configuration

Configuration parameters are network or switch specific and are configured and stored on the WLAN Switch. Network configuration settings are pushed out to the AP(s) but remain stored on the WLAN Switch. Configuration settings can be configured via the AOS-W Web UI, AOS-W CLI, or Alcatel-Lucent OVM. Refer to their respective guides for further details: the *AOS-W User Guide* or *Alcatel-Lucent OmniVista Mobility Manager User Guide*.

Alcatel-Lucent Antennas

Before you can select the antenna type needed for the deployment, read the basic wireless antenna information provided in this section. This information will help you understand wireless antenna basics and Alcatel-Lucent antenna specifications.

Understanding Wireless Antennas

Omni-Directional vs. Directional Coverage

For optimal performance of your wireless network, it is essential to understand the purpose behind proper antenna selection. Choosing the correct antenna type will ensure that RF energy is being directed to the correct coverage areas. Omni-directional antennas provide equal coverage in all directions (see [Figure 22](#)), while directional antennas point RF energy in a specific direction for RF concentration within a targeted area (see [Figure 23](#)).

Figure 22 *Omni-Directional Antenna*

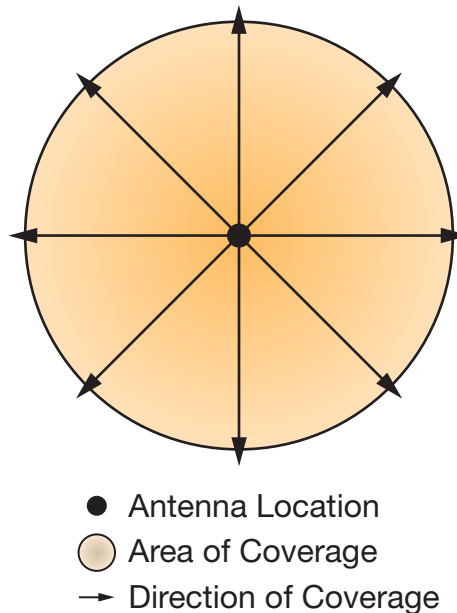
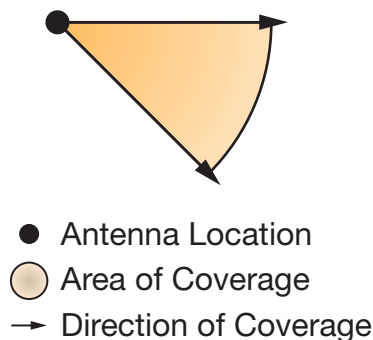

Figure 23 *Directional Antenna*



Antenna Beamwidth, Pattern, and Gain Considerations

Antenna gain is a relative measure of how the antenna compares to an ideal isotropic radiator. An ideal, isotropic radiator would radiate power in all directions equally over a sphere. The relationship between gain, power, and propagation distance is detailed already in textbooks and Wiki's, so these expressions are not repeated here. Antenna gain is often confused with power gain in amplifiers, but it is important to note that antenna gain only makes a transmitter's power appear to be higher than would be predicted by calculation of the power fed to the antenna and then spread equally over a sphere. Antenna gain itself is a completely passive and bi-directional property, determined only by the shape and construction of the antenna.

Knowing that gain is only a comparison of the apparent power to the power that would be required if fed to an ideal isotropic antenna, you realize that gain can only be created by distorting the antenna pattern from the ideal spherical pattern. Think of this as focusing the same power that would normally distribute evenly over a sphere into a tighter region of space. Thus, the higher the gain, the more concentrated (in some way) the antenna pattern must be in order to achieve that gain.

Example

To visualize the concept of gain, picture a rubber ball. The surface area of the ball represents the total available power radiated by an ideal isotropic antenna over its sphere of radiation (see [Figure 24](#)).

Figure 24 *Equal Signal Strength Radiated in All Directions*

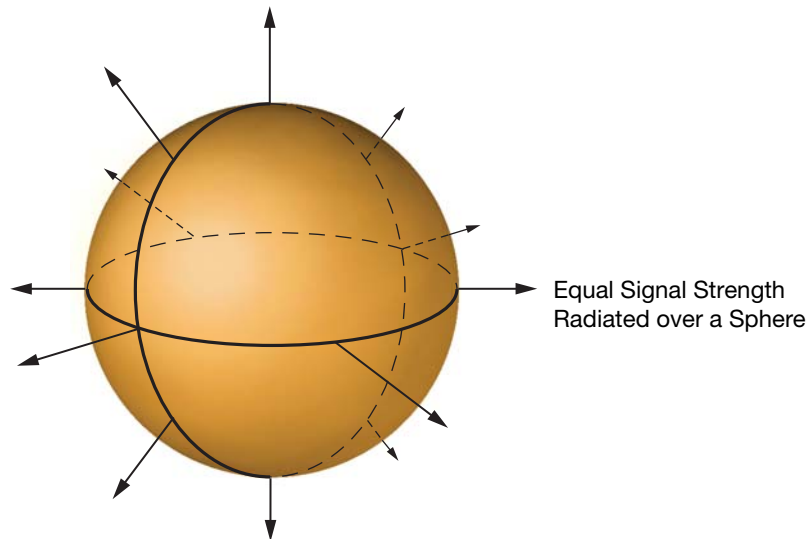

Now, still using the same ball with the same available surface area, how would you be able to stretch the ball farther out? One way is to press down on the top of the ball and squash it down vertically. This would keep the same basic shape in the horizontal plane (round), but it would force the ball to stretch, creating a pancake shape, in the vertical direction (see [Figure 25](#)). This represents the concept of the high gain omni-directional antenna, which achieves a greater coverage distance in the horizontal direction at the expense of coverage in the vertical areas of the radiating sphere.

Figure 25 High Gain Omni-Directional Antenna

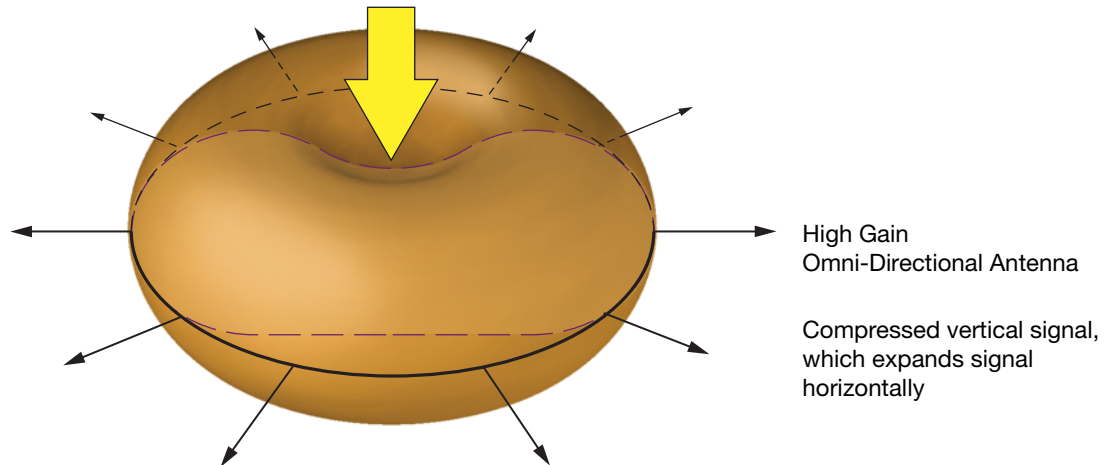

To stretch the ball primarily in one direction (instead of in all directions), push the ball, both vertically and horizontally, on the sides and on the back, to force the ball to deform in a single direction. This action would significantly distort the shape of the original ball both horizontally and vertically, but it will allow you to stretch the same ball a lot farther in one direction (see [Figure 26](#)). This represents the concept of the high gain directional antenna, which is designed to compress the entire radiating sphere into a single predominate direction.



Gain is created by forcing transmitted power to radiate in a preferred direction rather than radiating in all directions of an ideal sphere. Therefore, a high gain signal is always accompanied by loss of available signal in some other portion of the ideal sphere. High gain directional antennas are ideal for sites requiring directed coverage in a specific area or extended range for bridging applications, but they are not suited for sites requiring uniform coverage in large areas. It is important to keep in mind that both vertical and horizontal coverage can be affected by the use of a higher gain antenna and beamwidth (a measure of coverage) is always inversely related to gain.

Figure 26 High Gain Directional Antenna

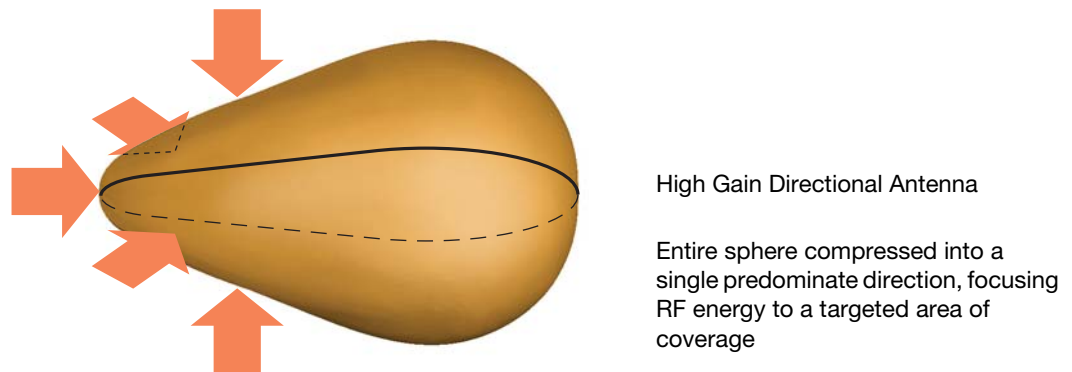

Understanding Antenna Pattern Plots and Specifications

Traditional 2-D pattern plots and beamwidth specifications are like mental puzzles waiting to be solved because they only provide a snapshot of the information in two planes. These two planes are often referred to as the azimuth (H-plane or horizontal) and elevation (vertical or E-plane) planes. The azimuth view would be considered the view from directly above, viewing the antenna pattern on the horizontal plane. The elevation view is considered to be a side view, viewing the antenna pattern on the vertical plane. It is helpful to think of these planes as “cuts” of the real antenna pattern, which is actually 3-D. [Figure 27](#) illustrates where these “cuts” are located for a typical omni-directional antenna pattern.

Figure 27 Antenna Pattern Conventions (Omni-Directional Pattern Shown)

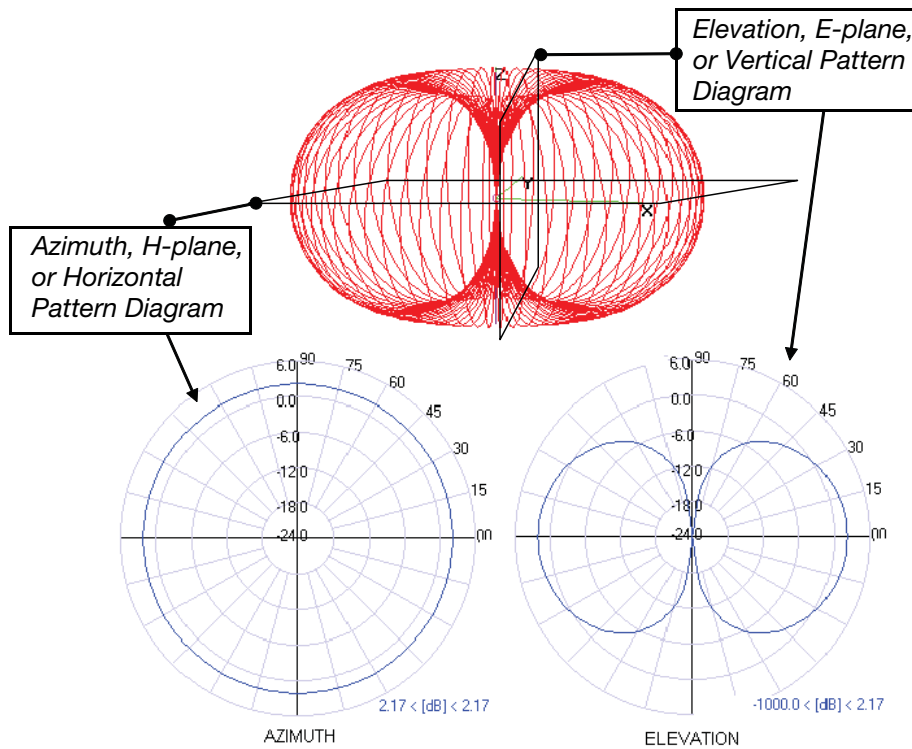

The antenna illustrated by [Figure 27](#) is commonly referred to as the dipole pattern because it is the pattern produced by an ideal dipole antenna. The gain of this antenna is 2.14, which is achieved by compression in the vertical plane (elevation) compared to the ideal sphere. If referring to the true 3D pattern, this compression is sometimes called the donut shape (see [Figure 28](#)).

Figure 28 Donut Shape Compression of an Omni-Directional Antenna

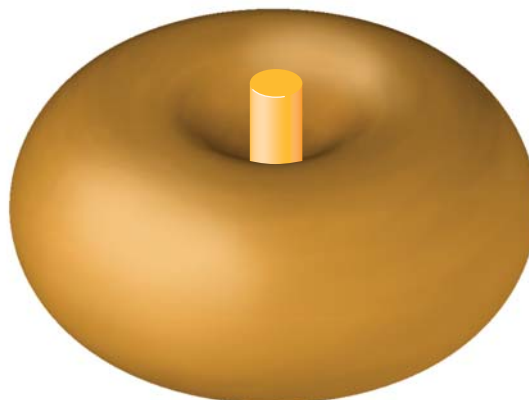

It is evident from [Figure 27](#) that 2-D pattern plots typically provided in antenna specifications are a simplification of the real 3-D situation. Often, 2-D plots are reduced even further to a set of simple specifications based on the antenna gain and 3 dB beamwidth.

Detachable Antenna Selection

Select the correct antenna type to support the required frequency band (2.4 GHz or 5 GHz) and desired coverage pattern.

To select the correct antenna type for the deployment, download and read Alcatel-Lucent's outdoor antenna specifications: <http://www.arubanetworks.com/products/access-points/antennas.php>.



All figures are shown with a 100 meter (328 feet) mounting height above the ground and for a 18 Mbps coverage area.

Detachable Outdoor Antenna Types

These are some of the terms used to describe Alcatel-Lucent's detachable antenna offerings. Terminology and degree of sector in Alcatel-Lucent's antenna specifications are determined by the horizontal 3 dB beamwidth.

- **Down-Tilt:** An omni-directional antenna that focuses its energy downwards.
- **Sector/Patch:** A directional antenna that provides a focused sector of coverage from a central point (Example: +/- 45 degrees from a 90 degree center point).
- **Panel:** A flat formed antenna that directs energy to a sector of coverage. This type of antenna is often ideal for point-to-point WDS bridging or wireless mesh backhaul applications.

Detachable Antenna Selection Tips

- If omni-directional coverage is desired with the greatest possible horizontal range from the AP, select one of Alcatel-Lucent's detachable antennas with high-gain, omni-directional coverage. Due to the tight vertical beamwidth of high-gain, omni-directional antennas, this typically requires mounting the antenna not more than 5 meters (16.5 feet) above the expected client locations in elevation.
- If omni-directional coverage is desired, but only high mounting locations are available (approx. 5 m (16.5 feet) to 10 m (33 feet)), consider the use of lower gain (3 dBi to 5 dBi) omni-directional antennas and a denser AP deployment. The lower gain antenna will reduce the maximum horizontal range of the AP, but will provide better vertical coverage.
- For very high mounting locations (>10 m/33 feet) such as light poles or monopoles, consider the use of an omni-directional antenna with electrical downtilt. A downtilt omni-directional antenna is an antenna that has a direction of maximum gain at approximately 45° down from horizontal.

Figure 29 AP-ANT-90 E-Plane View (Side View)

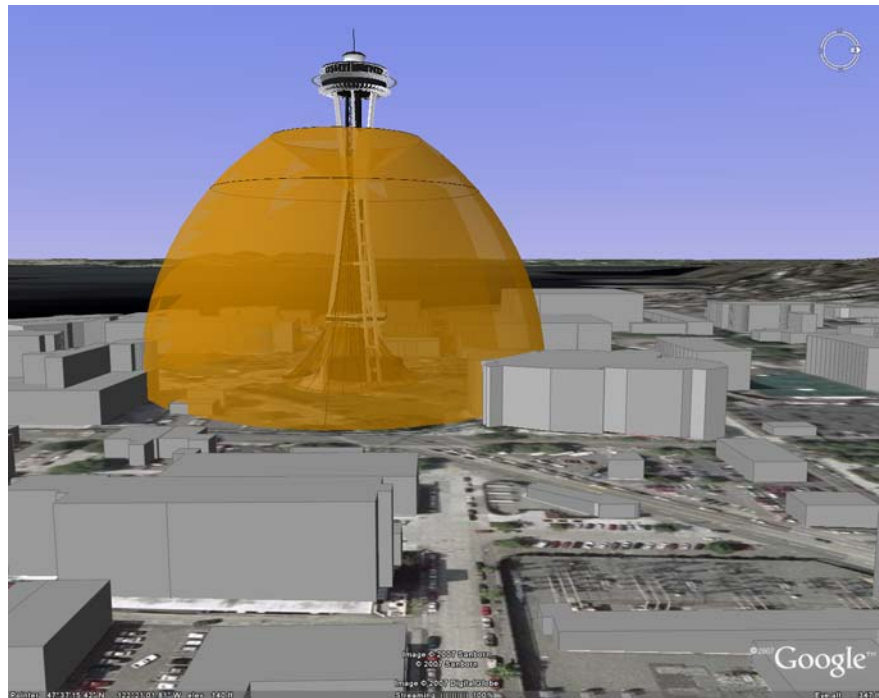
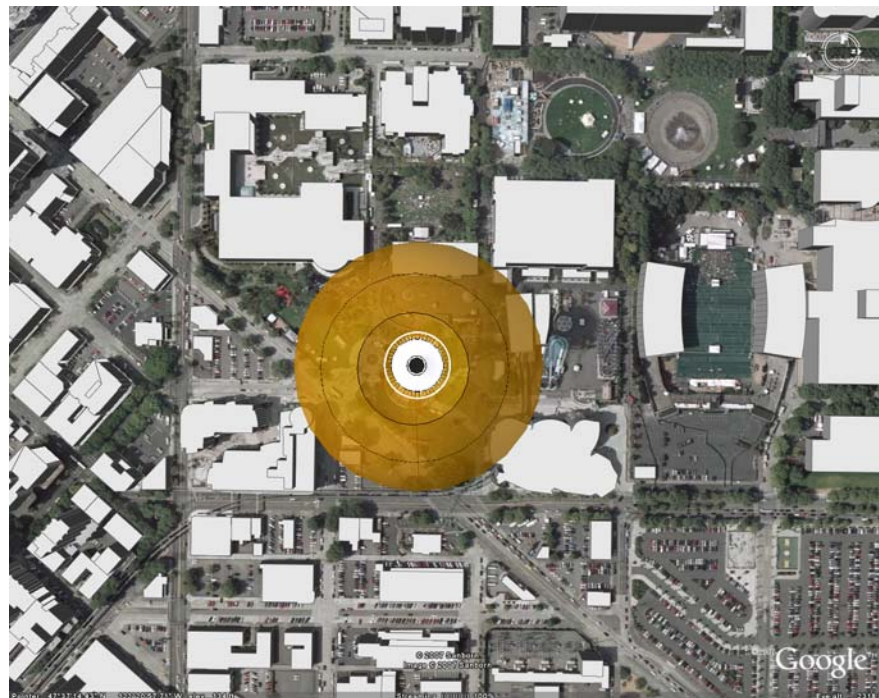

Figure 30 AP-ANT-90 H-Plane View (Top View)



- Alternatively, for high mounting locations, high-gain sector antennas may be used with mechanical downtilt. This will typically require the use of multiple access points per mounting location to provide omni-directional coverage.
- If a directional antenna is required to direct RF coverage, the detachable antenna must be capable of supporting all of the frequency bands that require support (2.4 GHz and/or 5 GHz).
- Directional antennas are selected to focus RF energy more efficiently to a targeted area.
- Directional antennas are also useful in areas where the surrounding materials have high amounts of RF attenuation or reflection and the RF signal needs to be guided in the direction of the least

amount of attenuation or reflection. For example, when mounting antennas on the outside surfaces of a building to provide coverage to outdoor spaces in front of the building, a directional antenna can be used to direct the coverage away from the building.

High Mounting Omni-Directional Antenna Scenario (AP-ANT-80 vs. AP-ANT-90)

The AP-ANT-80 shows greater horizontal range due to its higher gain (8 dBi vs. 3 dBi) antenna, but in this very high mounting situation, the AP-ANT-90 may be a better choice for ground level coverage because the direction of maximum gain is directed downward toward the ground. This situation could potentially be improved if a lower mounting elevation was available for the AP-ANT-80, ideally about 5 m above Ground.

Figure 31 AP-ANT-80 E-Plane View (Side View)



Figure 32 AP-ANT-80 H-Plane View (Top View)

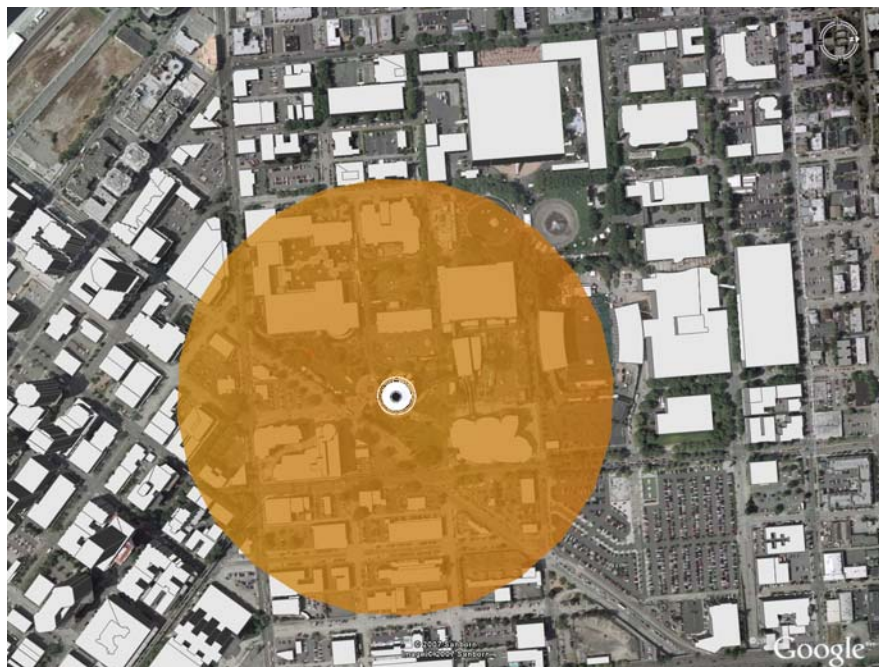

High Mounting Directional Antenna Scenario

The AP-ANT-82 is a high gain (12 dBi), directional antenna with a 90 degree 3 dB beamwidth in azimuth. For this high mounting condition, this antenna provides a long range in the direction of maximum gain, but it would require mechanical downtilt for ground level coverage.

Figure 33 AP-ANT-82 E-Plane View (Side View)

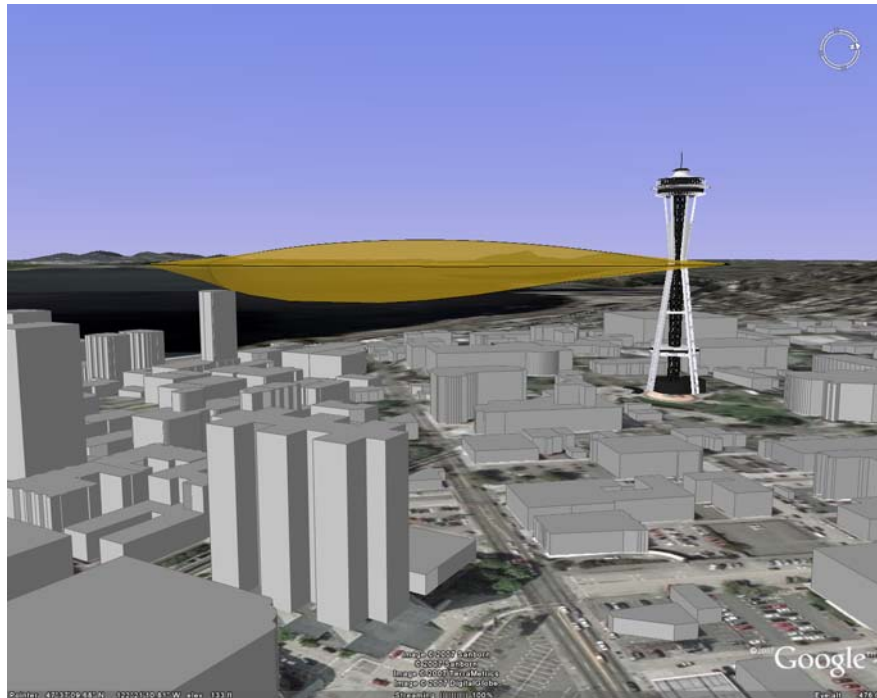

Figure 34 AP-ANT-82 with 30 Degree Downtilt E-Plane View (Side View)

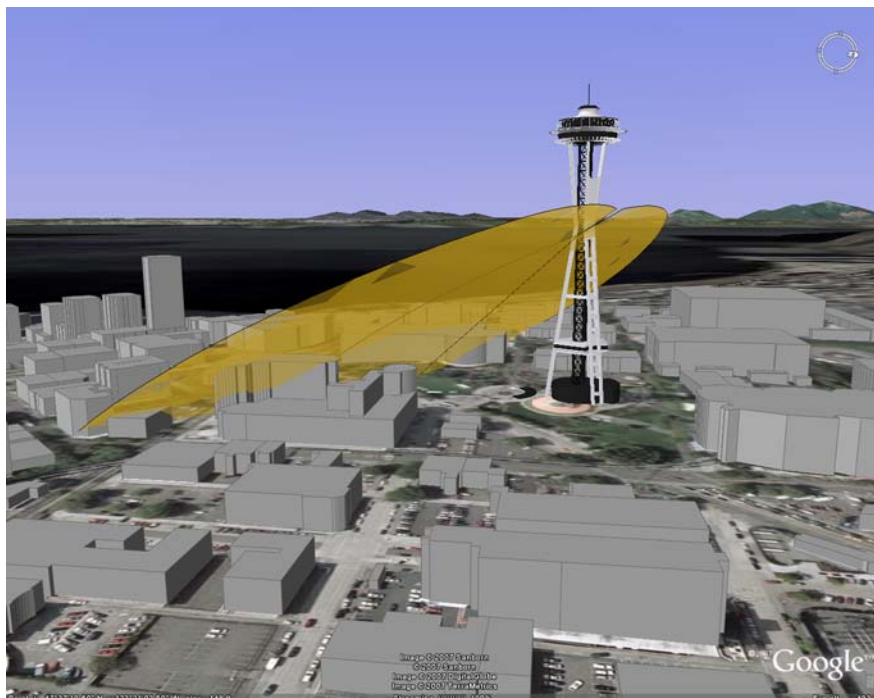

Figure 35 AP-ANT-82 H-Plane View (Top View)

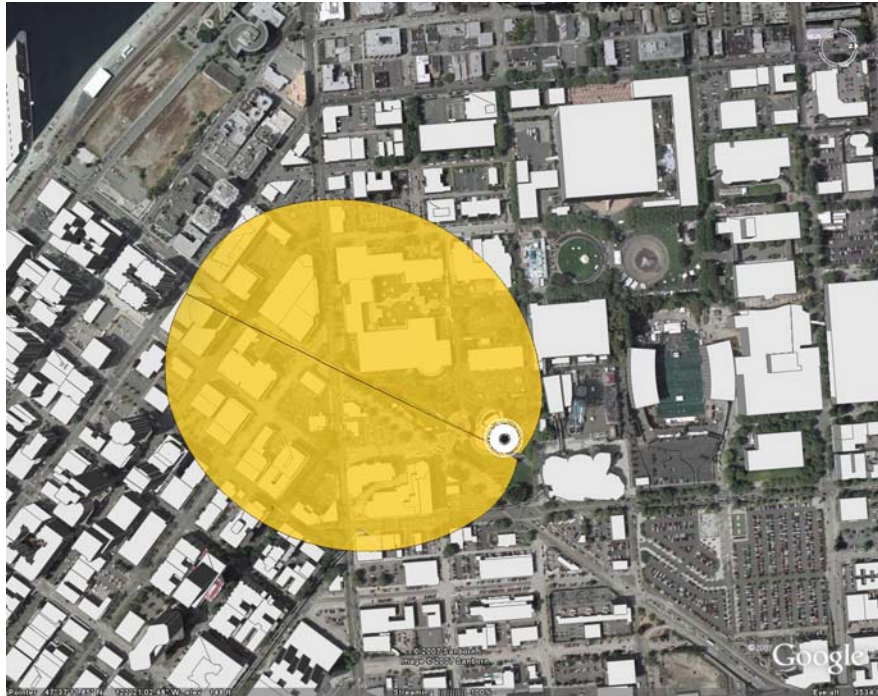
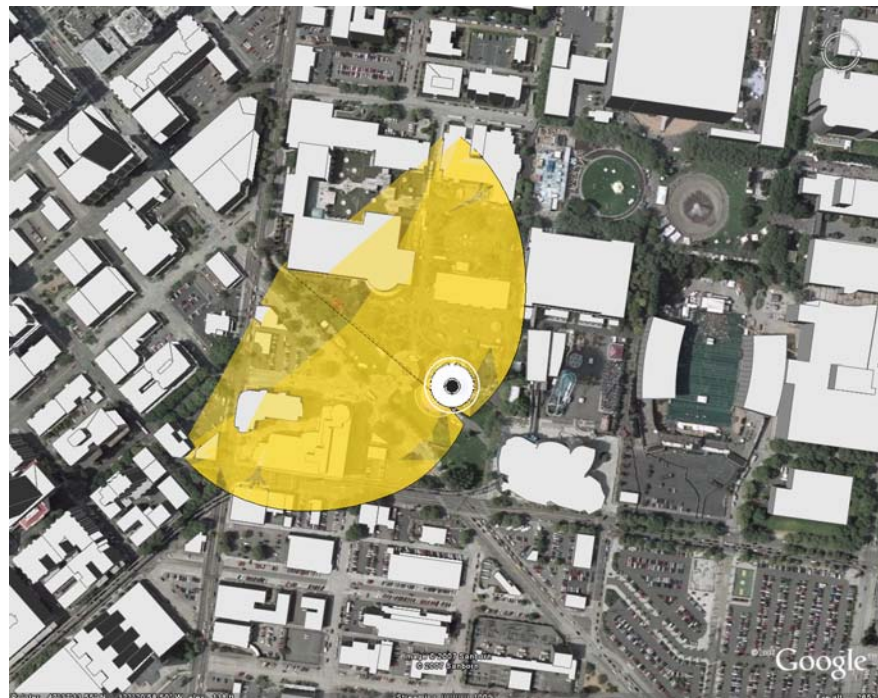

Figure 36 AP-ANT-82 with 30 Degree Downtilt H-Plane View (Top View)



Product Specifications

Mechanical (OAW-AP85TX, OAW-AP85FX, and OAW-AP85LX)

- Device Dimensions (HxWxD):
 - 10.80" x 12.64" x 3.07"
 - 274 mm x 321 mm x 78 mm
- Device Weight: 7.40 lbs/3.36 kgs
- Device Weight with Mounting Plate: 9.65 lbs/4.38 kgs
- Device Weight with Mounting Plate and Mounting Bracket: 10.85 lbs/4.92 kgs
-
- Temperature:
 - Operating: -30°C to 55°C (-22°F to 131°F)
 - Storage: -40°C to 70°C (-40°F to 158°F)
- Relative Humidity: 0% to 95% non-condensing
- Altitude: 0-3000 m (0-9850 ft)
- Survival Wind Speed: 125 mph (201 km/hr)
- Mounting:
 - Articulating adjustable pole or mast mount kit (included)
 - Antenna mount bracket (optional)
- Antenna: Quad, N-type Female interfaces for external antenna support
- Ground: Electrical safety/ground terminal point
- Visual Status Indicators (LEDs):
 - Onboard LED array for RSSI level reading
 - PWR - Power/Status
 - LINK/ACT - LAN/Network Link Status
 - RADIO 0 - Radio 0 Status
 - RADIO 1 - Radio 1 Status
 - RSSI (Radio 0) - RSSI Level for Radio 0
 - RSSI (Radio 1) - RSSI Level for Radio 1

Electrical

OAW-AP85TX

- 1 x 10/100 Base-T auto-sensing Ethernet (RJ-45) Interface
 - IEEE 802.3 BaseT and 802.3u 100BaseTX compliant
 - PoE 48V DC Power over Ethernet (IEEE 802.3af compliant)
 - Serial over Ethernet (SoE)
 - Auto-sensing MDI/MDX
- 1 x 12 V DC / up to 2.0 A power interface (for external solar supplied DC power)
- 1 x Electrical Ground / Safety Terminal
- Fully environmentally hardened connector types (all interfaces)

OAW-AP85FX

- 1 x 100BASE-FX data uplink port for multi-mode, dual-fiber connectivity
 - 1310 nm wavelength, 2 km over MMF Interface
 - LC fiber optic connector type
- 1 x 12 V DC up to 2.0 A power interface (for external solar supplied DC power)
- 1 x 90-228 V~ / 500 mA auto-sensing power interface with transient power surge suppression
- 1 x Serial Console Port
- 1 x Electrical Ground / Safety Terminal
- Fully environmentally hardened connector types (all interfaces)

OAW-AP85LX

- 1 x 100BASE-LX data uplink port for single-mode, dual-fiber connectivity
 - 1310 nm wavelength, 10km over SMF
 - LC fiber optic connector type
- 1 x 12 V DC up to 2.0 A power interface (for external solar supplied DC power)
- 1 x 90-228 V~ / 500 mA auto-sensing power interface with transient power surge suppression
- 1 x Serial Console Port
- 1 x Electrical Ground / Safety Terminal
- Fully environmentally hardened connector types (all interfaces)

Maximum Power Draw

Table 6 OAW-AP85 Series Maximum Power Draw

AP Model	Power Source	Measurement Condition	Max Current (Amps)	Max Power (Watts)
OAW-AP85TX	PoE	48 V	0.25	12
OAW-AP85TX, OAW-AP85FX, OAW-AP85LX	DC	12 V	0.8	9.6
OAW-AP85FX, OAW-AP85LX	AC	240 V, 60 Hz	0.18 (RMS)	20.14

Wireless LAN

- Network Standards - IEEE 802.11b, IEEE 802.11g and IEEE 802.11a
- Antenna Type - None. Detachable, outdoor rated, 2.4 or 5 GHz antenna options available
- Radio Technology:
 - 802.11a/g - Orthogonal Frequency Division Multiplexing (OFDM)
 - 802.11b - Direct Sequence Spread Spectrum (DSSS)
- Radio Modulation Type:
 - 802.11a - BPSK, QPSK, 16-QAM, 64-QAM
 - 802.11b - DQPSK/CCK, DQPSK, DBPSK
 - 802.11g - OFDM, DQPSK/CCK, DQPSK, DBPSK
- Media Access Control - CSMA/CA with ACK
- Data Rates:
 - 802.11a - 6, 9, 12, 18, 24, 36, 48 and 54 Mbps per channel
 - 802.11b - 1, 2, 5.5, 11 Mbps per channel
 - 802.11g - 1, 2, 5.5, 6, 9, 11, 12, 22, 24, 33, 36 and 54 Mbps per channel
- Transmit and Available Channels: Determined by country of use and Alcatel-Lucent certifications within country of use

Safety and Regulatory Compliance

Alcatel-Lucent provides a multi-language document containing country specific restrictions and additional safety and regulatory information for Alcatel-Lucent hardware products. The *Alcatel-Lucent Safety and Regulatory Addendum* can be viewed or downloaded from the following location: <https://service.esd.alcatel-lucent.com>.



Alcatel-Lucent Access Points and the AP-LAR-1 lightning arrestor are required to be installed by a professional installer. The professional installer is responsible for ensuring that grounding is available and it meets applicable local and national electrical codes.



Do not work on an AP and do not connect or disconnect cables during periods of lightning activity.

Proper Disposal of Alcatel-Lucent Equipment

For the most current information on Global Environmental Compliance and Alcatel-Lucent products please see our website at www.alcatel-lucent.com.

Waste of Electrical and Electronic Equipment



Alcatel-Lucent products at end of life are subject to separate collection and treatment in the EU Member States, Norway, and Switzerland and therefore are marked with the symbol shown at the left (crossed-out wheellie bin). The treatment applied at end of life of these products in these countries shall comply with the applicable national laws of countries implementing Directive 2002/96EC on Waste of Electrical and Electronic Equipment (WEEE).

European Union RoHS



Alcatel-Lucent products also comply with the EU Restriction of Hazardous Substances Directive 2002/95/EC (RoHS). EU RoHS restricts the use of specific hazardous materials in the manufacture of electrical and electronic equipment.

Specifically, restricted materials under the RoHS Directive are Lead (including Solder used in printed circuit assemblies), Cadmium, Mercury, Hexavalent Chromium, and Bromine. Some Alcatel-Lucent products are subject to the exemptions listed in RoHS Directive Annex 7 (Lead in solder used in printed circuit assemblies). Products and packaging will be marked with the “RoHS” label shown at the left indicating conformance to this Directive.

China RoHS



Alcatel-Lucent products also comply with China environmental declaration requirements and are labeled with the “EFUP e” label shown at the left.

A			
AC power	12		
AC power cable	29		
access point setup	21		
accessories	13		
antenna	31		
beamwidth	32		
detachable selection	35		
directional	31		
gain	32		
height	17		
installation	30		
interfaces	10		
omni-directional	31		
orientation	18		
pattern	32		
pattern plots	34		
position	18		
specifications	34		
understanding of	31		
wireless	31		
AOAW-AP85TX			
interfaces	10		
B			
beamwidth	32		
C			
cables	28		
cabling	19, 28, 29		
configuration	30		
connecting cables	28, 29		
connectivity	22, 30		
console port	11		
customer support	6		
D			
DC power	10, 11		
DC power cable	29		
deployment	15		
detachable antennas	35		
		directional antenna	31
E			
		environment	19
		ethernet cabling	19
F			
		fiber interface	11
G			
		gain	32
		grounding	19
		grounding point	11, 12
I			
		installation	21, 22, 23
		configuration	30
		pole mounting (>3.5" Diameter)	26
		pole mounting (1.5" to 3.5" Diameter)	24
		positioning	27
		post-installation connectivity	30
		preparation	23
		wall mounting	23
L			
		LC connector	11
		LEDs	12
		lightning arrestor	10, 30
		line of sight	16
M			
		mounting	23
		multi-mode fiber interface	11
N			
		network setup	21
		N-type antenna interfaces	10
O			
		OAW-AP85 Series	

about	7	power over ethernet	10
antenna interfaces	10	pre-installation	23
bottom view		checklist	21
OAW-AP85TX model	10	connectivity	22
cable connection	28	network setup	21
configuration	30	provisioning	22
front view	9	provisioning	22
installation	22		
LEDs	12	R	
overview	9	radio interference	19
package checklist	8	radio path planning	16
power cable connection	29	regulatory compliance	43
rear view	9	RF absorbers	15
RJ-45 cable connection	28	RF interference sources	15
software requirements	8	RF reflectors	15
specifications	41	RJ-45 cable	28
top view	10	RSSI LEDs	12
OAW-AP85FX		RSSI levels	13
100Base-FX	11	S	
console port	11	safety	43
multi-mode fiber	11	scale requirements	15
OAW-AP85LX		serial console port	11
100Base-LX	11	serial power over ethernet	10
console port	11	single-mode fiber interface	11
single-mode fiber	11	software requirements	8
OAW-AP85TX		specifications	41
10/100Base-T ports	10	SPoE	10
LAN	10	status indicators	12
PoE	10	support, customer	6
SPoE	10	W	
omni-directional antenna	31	wall mounting	23
operation		weather	19
modes of	7	wireless antenna	31
outdoor conditions	19		
outdoor deployment	15		
outdoor planning	15		
overview	9		
P			
package checklist	8		
planning	15		
PoE	10		
pole mounting (1.5" to 3.5" Diameter)	24		
pole moutning (>3.5" Diameter)	26		
positioning	27		
post-installation	30		
power			
AC	12		
DC	10, 11		
power cables	29		

